

(12) AUSTRALIAN PATENT ABRIDGMENT

(19) AU

549294

(11) AU-A-15051/83

- (54) BUILDING WITH WALL PANELS SECURED BY GANG NAIL PLATES TO STRUTS, ROOF AND FLOOR MEMBERS
- (75) RUSSELL HALL
- (21) 15051/83 549294 (22) 27.5.82 (24) 27.5:82
- (23) 27.5.83
- (43) 1.12.83 (44) 23.1.86
- (51)3 E04B 2/56 E04B 2/70 E04H 9/14
- (74) CU
- (56) 35307-71 453339 E04B 2/00
29711-49 (L) E04B 1/343

(57) Claim

1. A building structure of the type comprising a roof assembly, a floor supporting assembly and wall assemblies extending upwardly from said floor supporting assembly and supporting said roof assembly, characterized in that said wall assemblies are formed from a plurality of prefabricated wall frame assemblies each of which includes vertically spaced upper and lower timber chords; a pair of spaced timber studs extending between said upper and lower timber chords and being connected thereto adjacent respective ends thereof by respective multiple nail plate type connectors, and bracing means interconnecting said upper and lower timber chords and arranged to prevent distortion of said prefabricated wall frame assembly, and there being provided wall cladding extending between said chords and secured to respective inner or outer faces of said chords and said studs, and said roof assembly being tied to said floor supporting assembly to prevent lifting of the roof assembly by a first set of

549294

This document contains the amendments made under Section 44, and is correct for printing.

This document contains the amendments allowed under Section 83 (2) by the Superintending Examiner and is correct for printing.

COMMONWEALTH OF AUSTRALIA

The Patents Act 1952-1960

15051/83

Name of Applicant: RUSSELL HALL
Address of Applicant: 8 MAIN STREET, BUDERIM, QLD. 4756

Actual Inventor: RUSSELL HALL
Address for Service: ~~G.R. GULLEN & COMPANY, Patent & Trade Mark Attorneys, 232 Green Street, Brisbane, in the State of Queensland, Commonwealth of Australia.~~
Attn: 21/63

COMPLETE SPECIFICATION FOR THE INVENTION ENTITLED:

"IMPROVED BUILDING SYSTEM"

The following statement is a full description of the invention including the best method of performing it known to us:

BAD ORIGINAL

This invention relates to an improved timber building system and components therefore.

In recent years design requirements for timber buildings have become more stringent in order that buildings such as dwellings are able to withstand high wind loads. A primary consideration has been to provide hold-down means securing the roof structure to the floor structure of the building to prevent lifting of the roof and consequent collapse of the building. At present, long through bolts are used for this purpose. They extend through the roof rafters and the floor bearers or equivalent structure to tie the roof to the floor. The provision of such hold-down means is effective in use but unfortunately it adds markedly to the cost of construction of conventional dwellings.

It is an object of the present invention to alleviate the abovementioned disadvantages associated with such building systems and to provide an improved building system, which will be reliable and efficient in use. Other objects and advantages of this invention will hereinafter become apparent.

With the foregoing and other objects in view, this invention in one aspect resides broadly in a building structure of the type comprising a roof assembly, a floor supporting assembly and wall assemblies extending upwardly from said floor supporting assembly and supporting said roof

assembly, characterized in that said wall assemblies are
formed from a plurality of prefabricated wall frame assemblies
each of which includes vertically spaced upper and lower
timber chords; a pair of spaced timber studs extending between
5 said upper and lower timber chords and being connected thereto
adjacent respective ends thereof by respective multiple nail
plate type connectors, and bracing means interconnecting said
upper and lower timber chords and arranged to prevent
distortion of said prefabricated wall frame assembly, and
10 therebeing provided wall cladding extending between said
chords and secured to respective inner or outer faces of said
chords and said studs, and said roof assembly being tied to
said floor supporting assembly to prevent lifting of the roof
assembly by a first set of fastenings connecting the roof
15 assembly to said top chords and a second set of fastenings
connecting said floor supporting assembly to said lower
chords.

In one form each prefabricated wall frame assembly
comprises top and bottom timber chords interconnected at each
20 end and medially by a timber stud or studs and there are
provided timber diagonal braces extending between the studs.
Preferably nogging is supported between the studs and the
timber diagonal braces extend from the junction between the
end studs and the nogging to the respective upper and lower
25 ends of the intermediate stud(s). The frame may be faced with

suitable cladding at one side only to form a single skin panel or alternatively it may be faced on both sides to form a double skin panel. Suitably the panel sizes are made to accept full sheets of conventional sized cladding to form a module which may be utilized in modular constructions in order to maximize use of materials and also to simplify construction techniques.

5
10
15
Panels according to the invention provide a structure which is capable of transmitting a tensile or parting load applied between the top and bottom chords, such as the loads applied by strong wind passing across a building roof whereby the respective top and bottom chords may be connected to the respective roof assembly and floor supporting assembly to tie the roof assembly to the floor supporting assembly.

20
25
The top and bottom chords of the wall frame assemblies may be continuous along a wall section which may constitute for example one side wall of a building, or the top and bottom chords may comprise a plurality of separate members each associated with a respective one of a plurality of wall frame assemblies adapted to be connected in end to end abutting relationship to form a wall section. Preferably in the latter construction the respective bottom and/or top chords are interconnected by a connecting plate assembly which overlaps the joints of the bottom and/or top chords to

interconnect same. This construction has the advantage that the separate wall frame assemblies are relatively light and easy to erect. However additional timber is used due to the doubling of the bottom and/or top chords by their associated connecting plates. In the former construction utilizing continuous top and/or bottom chords along a wall, the timber usage is less since there is no requirement for a doubling or connecting plate. However such frames may be more difficult to erect due to their extra length and weight.

In order that the invention may be more readily understood and put into practical effect reference will now be made to the accompanying drawings, wherein:-

FIGS 1 to 4 are side views of typical wall frames according to the invention;

FIGS 5 and 6 are side views of typical wall panel modules made in accordance with the present invention;

FIG 7 is an end elevational view of a side portion of a building constructed in accordance with the present invention;

FIG 8 shows alternate floor mounting details, and FIGS 9 and 10 illustrate typical dwellings made according to the present invention.

As shown a dwelling 10 or other building made in accordance with one aspect of the present invention includes a

floor structure 11 and a wall assembly 12 supporting a roof assembly 13. In the embodiment illustrated in FIGS 7 and 9, the floor supporting structure 11 is elevated above the ground by posts 9 and includes a plurality of bearers 14 and joists 24 arranged in conventional manner. A bottom plate 15 is supported peripherally around the floor supporting structure 11 to support the bottom chord 16 of each timber wall frame assembly 17 whereby the latter may be erected to provide an enclosure above which the roof assembly 13 is supported.

10 In the arrangement illustrated in FIG 5 and FIG 9, each timber wall frame assembly 17 is in the form of a rectangular perimeter frame assembly 18 incorporating a timber bottom chord 16 and a timber top chord 19 interconnected by spaced timber studs 20 and braced by diagonal timber bracing members 21 and timber nogging 22. The interconnection at each junction of the timber frame members is formed by a multiple nail plate type connector 23. These connector plates 23 are secured to the timber frame members on both inside surfaces thereof so that separating loads may be transmitted from member to member and whereby each wall frame assembly 17 may effectively transmit both the compression and tension forces applied by the roof structure 13. These forces result from the weight of the roof structure and from wind loadings which tend to lift the roof structure 13 from the building.

25 A suitable connection between the frame assembly

17, the roof structure 13 and the floor structure 11 may be achieved economically by through bolting. For this purpose relatively short bolts 25 may be arranged to pass through the bottom chord 16 of each frame assembly 18 and through the bottom plate 15, the joists 24 and the bearers 14, as illustrated in FIG 7, so that the frame assembly 18 is positively attached to the floor structure 11. Of course the bearers are connected in known manner by hold-down brackets or bolts 26 to the posts 9. Similarly, the top plate 27 of the roof structure 13 is through bolted by bolts 28 to the top chord 19 of the frame assembly 17. The use of the short hold-down bolts 25 and 26 in lieu of the conventional full length bolts which extend from roof to floor greatly simplifies erection of a building made according to this invention.

The top plate 27 is fixed to the roof rafter 29 in conventional manner such as by plate-type connectors (not shown) which secure the rafters 29 to the top plate 27 and similarly the battens 30 which support the roof sheeting 32 are connected to the rafters by suitable metal brackets 31. In this manner lift forces imposed on the roof structure by strong winds are transmitted through the securing bolts 28 to the wall frame assembly 17 which is capable of transferring the lifting load to the floor supporting structure 11 through its bolted connections with the bearers 14. Preferably the

through bolts 25 and 28 are placed through the chords 16 and 19 as close as possible to a stud 20 so as to transfer the load directly through the gang nail connectors into the studs 20.

5 The frame assembly 18 is further braced by the provision of cladding 33 fixed to the inside of the wall frame assembly 17. The cladding 33 may be of continuous panel-type material such as plywood or solid timber planking or the like.

The various wall constructions 40 to 43 as
10 illustrated in FIGS 1 to 4 utilize both square and rectangular shaped frame assemblies 17 and 17a. The assemblies 17 may be utilized in a wall 40 at either side of a door structure 44. The latter may include doors mounted between upright studs 45 which are preferably nailed by multiple nail plate type
15 connectors between the bottom plate 15 and the lower chord 46 of a truss 47. This truss 47 utilizes top and bottom chords, upright members and diagonal braces all interconnected by plate type connectors.

A further disadvantage of many present day timber
20 construction methods resides in that sufficient roof overhangs are not always provided since the amount of allowable roof overhang bears a relationship to the strength of the roof rafters. Generally, roof rafters are designed to fulfill the structural requirement for supporting the roof inwardly of the
25 walls. Their resultant size excludes the provision of large

overhangs since the rafters are generally too small to support the overhang. In a typical embodiment of the present invention a large roof overhang may be provided as at 50 in FIG 7 whereby the ends of the rafters 29 are supported by a 5 brace 51 arranged to support the outer end portion of the rafter 29. The brace 51 is suitably connected between rafters 29 and studs 20 of the frame assembly 17. The connections are suitably provided by multiple nail plate type connectors whereby the brace 51 not only supports the weight of the 10 rafter 29, but it is also capable of preventing the latter from lifting as a result of wind loadings on the roof. Preferably the brace 51 is utilized with a wall frame assembly 17 having inside cladding 33 only whereby free access may be gained to the studs 20 to provide the connection between inner 15 end of the braces 51 and an exposed stud 20.

In use, a building made in accordance with the present invention is constructed by prefabricating the frame assemblies 17 which may be clad on one or both sides before or after erection. The frame assemblies 17 are then stood in 20 place on bottom plate 15 of the floor structure and secured thereto by bolting or strapping or the like, whereby they provide an upright wall structure upon which the roof assembly 13 may be erected. The roof assembly 13 is then connected to the wall frame assemblies 17 such as by through bolting or by 25 other mechanical connector means. This may include nailing to

the upper chords 19 of the wall frame assemblies 17 or further
plate-type connectors or tie straps could be used in lieu of
through bolting to provide a secure connection between the
frame assembly 17 and the roof and floor structures. The
5 lower chords 16 of the wall frame assemblies 11 are similarly
connected to the floor structure by through bolting or the
like.

Since the top and bottom chords are connected to
the studs by multiple nail plate type connectors a load
10 applied to the chords may be transferred in pre-determined
manner so that the studs may be effectively loaded in tension
and compression by the appropriate force applied to the
chords. Thus the lifting force which may be applied to a roof
by wind loadings can be transmitted by the studs. Previously
15 studs were considered as compression members only and thus
additional steel rod straps were introduced to the structure
to withstand the possible tension forces in the wall
structure.

FIGS 8 and 10 herewith illustrate the application
20 of the wall frame assemblies 17 of the present invention for
support on a concrete slab 60. As will be seen, in this
embodiment the bottom chords 16 are bolted directly to the
slab 60 via cast in bolts 61 and flashing 52 is interposed
between the bottom chords 16 and the slab 60.

25 It will of course be realised that the above has

been given only by way of illustrative example of the present invention and all such modifications and variations thereto as would be apparent to persons skilled in the art are deemed to fall within the broad scope and ambit of the present invention
5 as defined in the appended claims.

10

15

20

25

THE CLAIMS DEFINING THE INVENTION ARE AS FOLLOWS:-

1. A building structure of the type comprising a roof assembly, a floor supporting assembly and wall assemblies extending upwardly from said floor supporting assembly and supporting said roof assembly, characterized in that said wall assemblies are formed from a plurality of prefabricated wall frame assemblies each of which includes vertically spaced upper and lower timber chords; a pair of spaced timber studs extending between said upper and lower timber chords and being connected thereto adjacent respective ends thereof by respective multiple nail plate type connectors, and bracing means interconnecting said upper and lower timber chords and arranged to prevent distortion of said prefabricated wall frame assembly, and there being provided wall cladding extending between said chords and secured to respective inner or outer faces of said chords and said studs, and said roof assembly being tied to said floor supporting assembly to prevent lifting of the roof assembly by a first set of fastenings connecting the roof assembly to said top chords and a second set of fastenings connecting said floor supporting assembly to said lower chords.

2. A building structure according to Claim 1, wherein said bracing means comprises timber bracing members each extending diagonally between spaced pairs of studs from a respective junction between a chord and a stud and being

connected thereto by said multiple nail plate type connectors.

3. A building structure according to Claim 2, wherein said multiple nail plate type connectors are secured at each junction between a chord and a stud and to both interior and exterior faces thereof.

4. A building structure according to Claim 2 or Claim 3, wherein there are provided nogging members supported between said studs and wherein said diagonal braces extend from the junction between said studs and said nogging members to the junction between said chords and said studs and wherein multiple nail plate type connectors are used to connect said nogging and said diagonal bracing members to the respective studs and chords.

5. A building structure according to any one of the preceding claims, wherein said bracing means comprises a unitary cladding panel fixed to said chords and studs.

6. A building structure substantially as hereinbefore described with reference to the accompanying drawings.

DATED THIS twenty-first DAY OF November, 1935.

RUSSELL HALL

by

PIZZEY & COMPANY PATENT ATTORNEYS



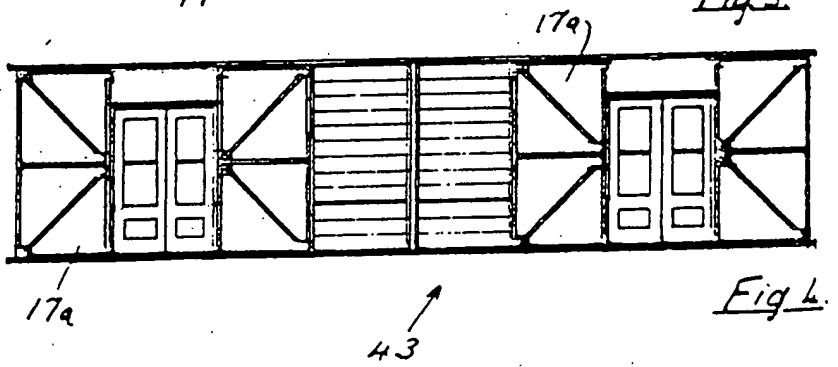
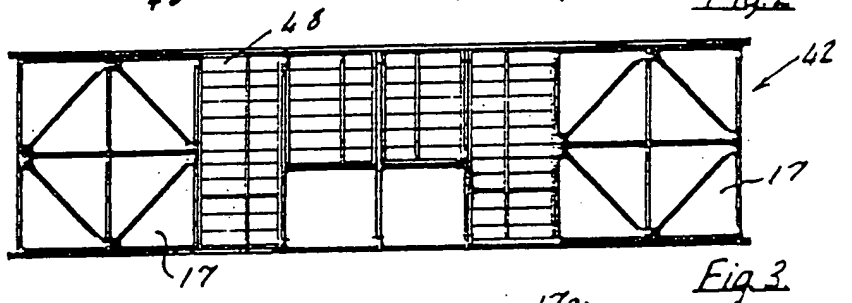
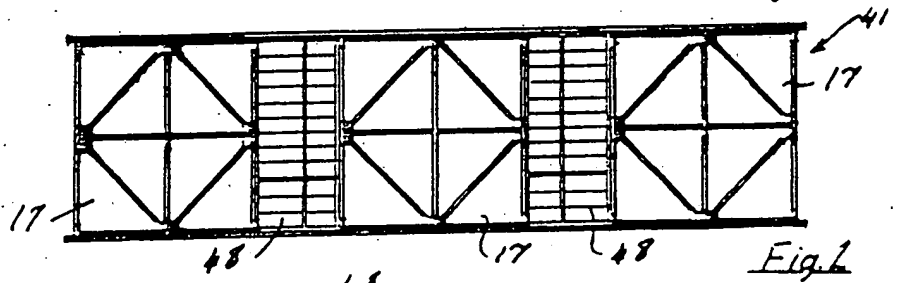
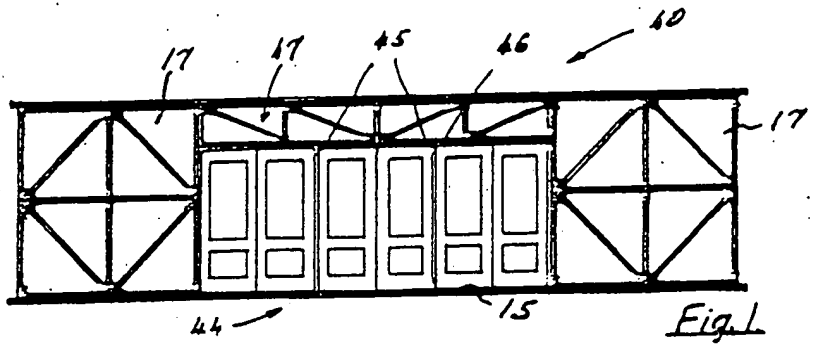

15051/83

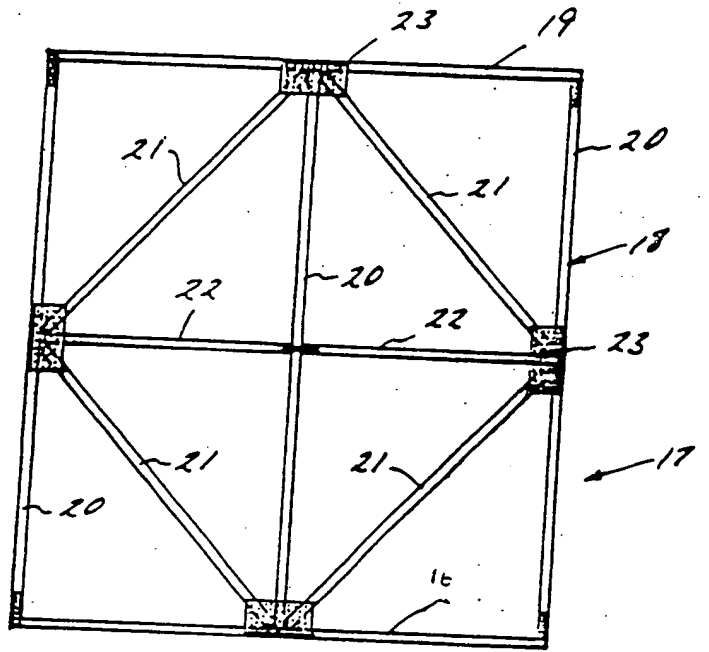

Fig. 5.

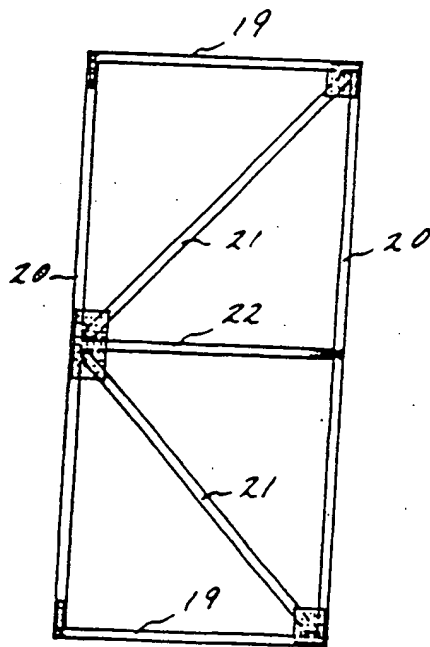
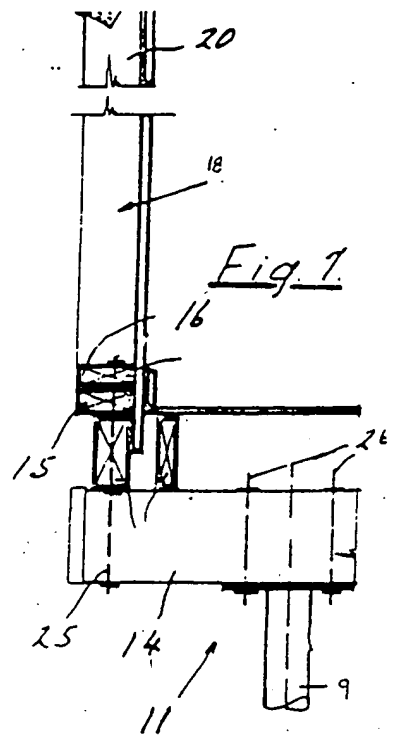
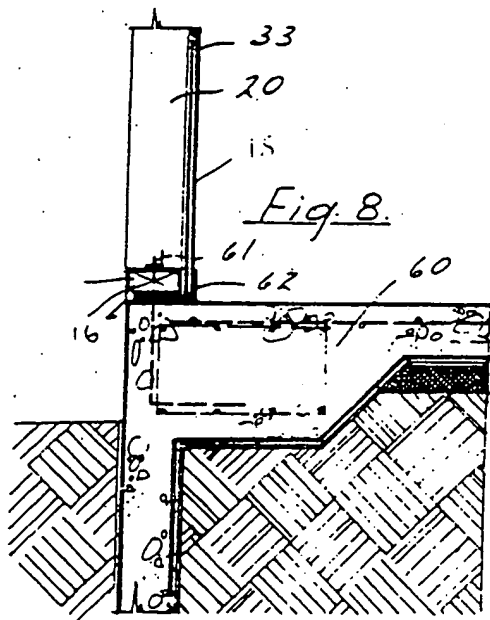
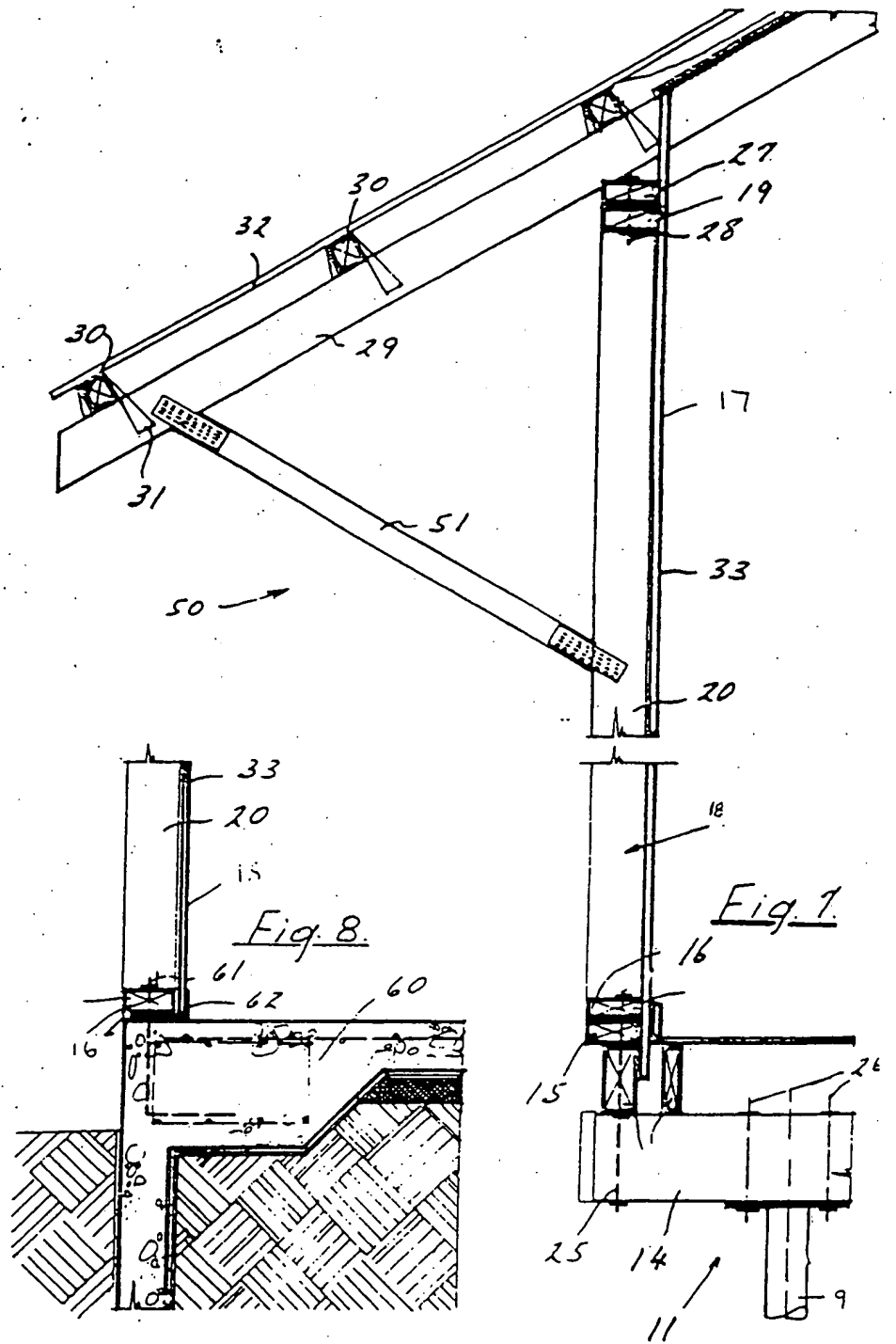

Fig. 6.





15 051/83

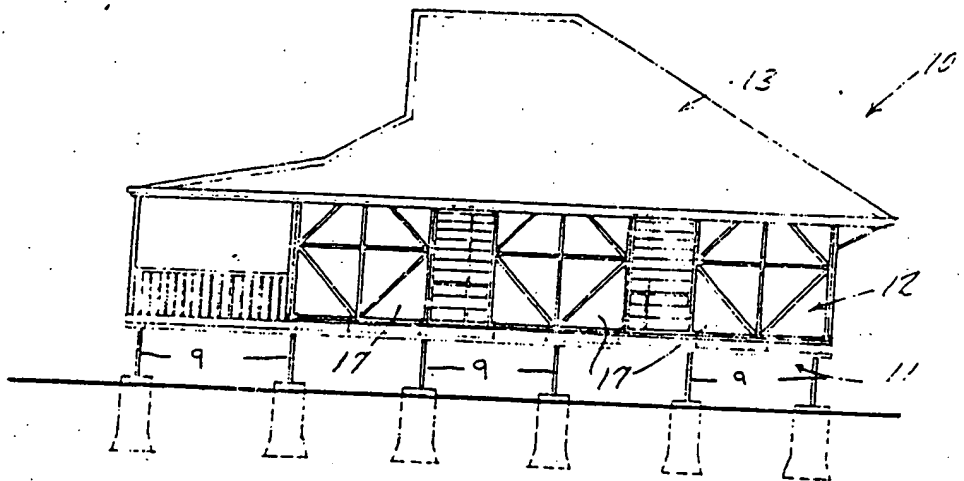

Fig. 9.

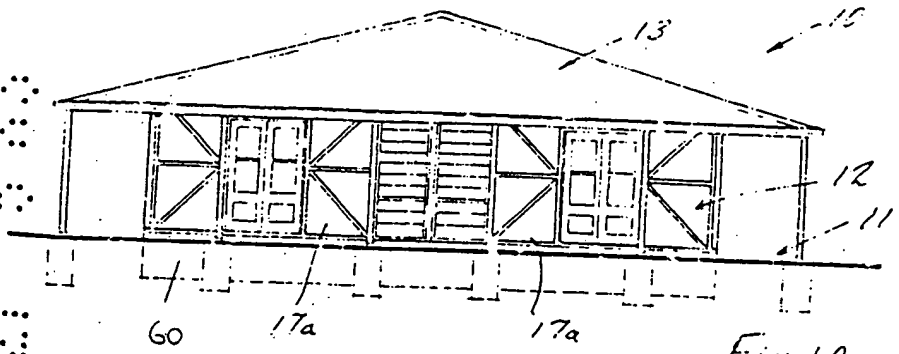

Fig. 10.

BAD ORIGINAL